



DEARBORN

INDUSTRIAL LOADER



MODEL 19-61

ASSEMBLY AND OPERATING INSTRUCTIONS

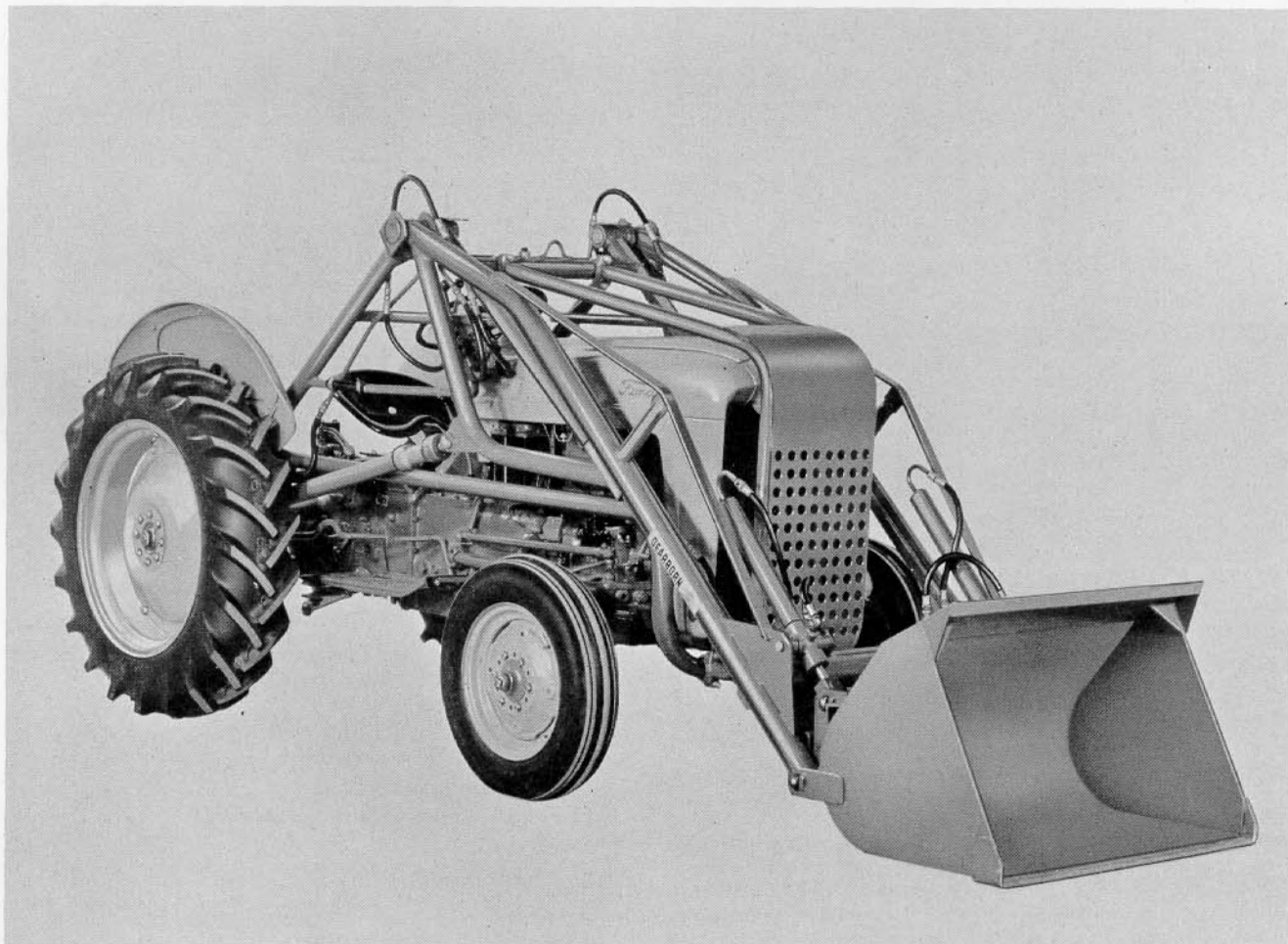

The Dearborn Industrial Loader was designed for you and your operator. In it you will find top loading performance and rugged low-cost service, and for your operator, maximum convenience and ease of control.

Top performance is assured by its high lift and high capacity, longer bucket over-hang and close-coupled design. Rugged, low-cost service because of tubular construction, two cylinder bucket control, full circulating hydraulic system for lower oil temperatures and an independent tractor mounted pump for a positive trouble-free hydraulic drive even under most adverse conditions.

Your operator will have maximum comfort and ease of operation because of full vision, convenient

controls, and ample elbow room, all combined with the easy maneuverability of the Ford Tractor.

For additional performance and versatility, other Dearborn Implements can be used on your Ford Tractor without removing your loader. These implements such as blades, scoops or subsoilers are operated by your effective Ford Tractor Hydraulic Touch Control Mechanism.

The Dearborn Industrial Loader, Model 19-61 is designed especially for the Ford Model NAA Tractor.

This manual contains information on the assembly, lubrication and general operation of your Dearborn Industrial Loader. Read it carefully, study the illustrations and keep it available for ready reference.

DEARBORN MOTORS CORPORATION

BIRMINGHAM, MICHIGAN

www.ntractorclub.com

DEARBORN INDUSTRIAL LOADER

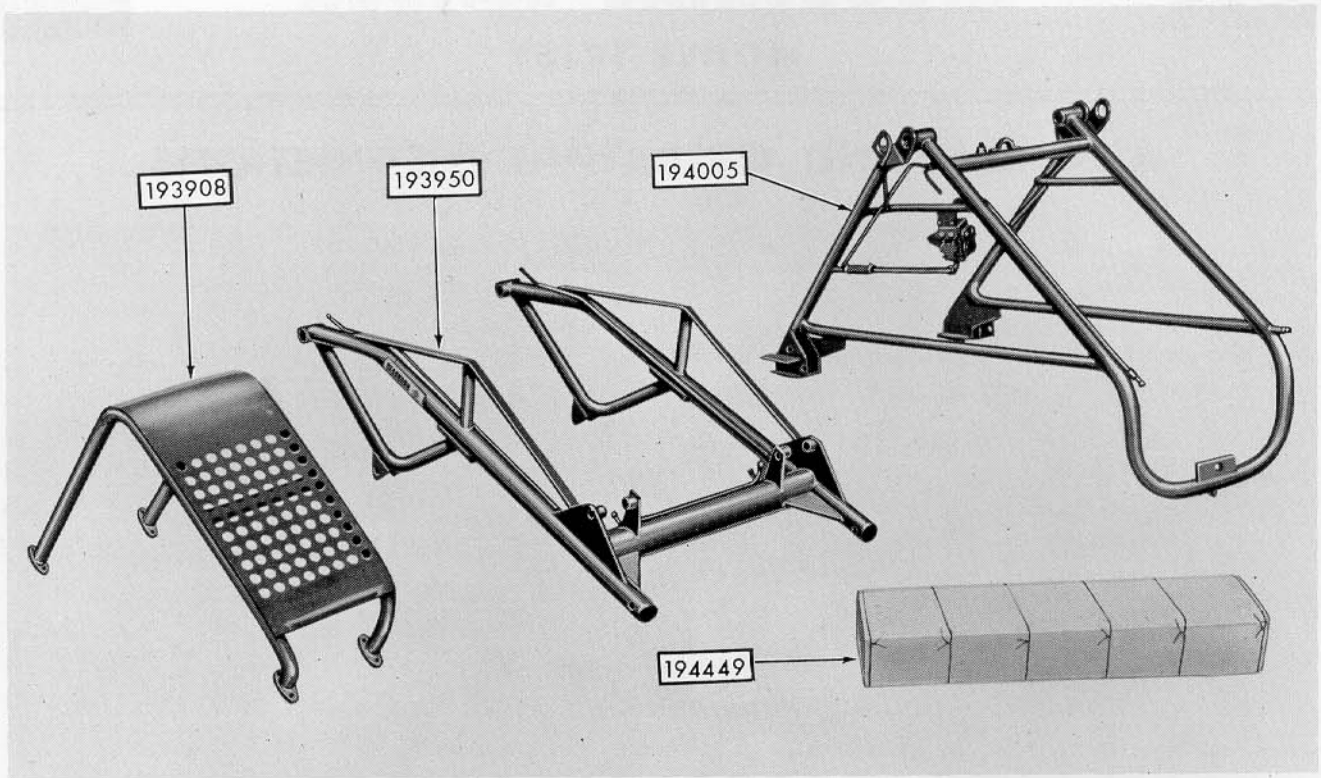

Figure 1
Dearborn Industrial Loader Bundled for Shipment

SHIPPING INFORMATION

The Dearborn Industrial Loader, Model 19-61, is shipped in four bundles as shown in Figure 1. Check the shipment against the following list and Figure 1 to be sure all parts are received.

D.M.C. Bundle No.	Description
193908	Bumper Assembly
193950	Lift Arm Assembly with Bucket Control Hydraulic Lines Attached
194005	Main Frame with Control Valve and equalizer pipe assembly attached
194449	Carton of miscellaneous parts

Bundle No. 194449 in the above list contains the parts listed below. One each of these parts is shown in Figure 2.

Item No.	Description	No. Required
1.	Hydraulic pump	1
2.	Bag containing miscellaneous parts	1
3.	$\frac{3}{8}$ " x 18" hose and couplings	12
4.	$4\frac{3}{4}$ " pivot pin	2
5.	Lift arm pivot pin	2
6.	Frame to pump pipe	1
7.	Control valve levers and bag of small parts	1
8.	$3\frac{7}{8}$ " pivot pin	6
9.	Front suspension plate	1
10.	Instruction manual	1
11.	Headlight bracket	2
12.	1" x 6" hose connection	1
13.	Complete drive assembly	1
14.	Bucket cylinder assembly	2
15.	Lift arm cylinder assembly	2

The Material Bucket illustrated in this manual is sold separately and is shipped in one bundle as Model 19-43.

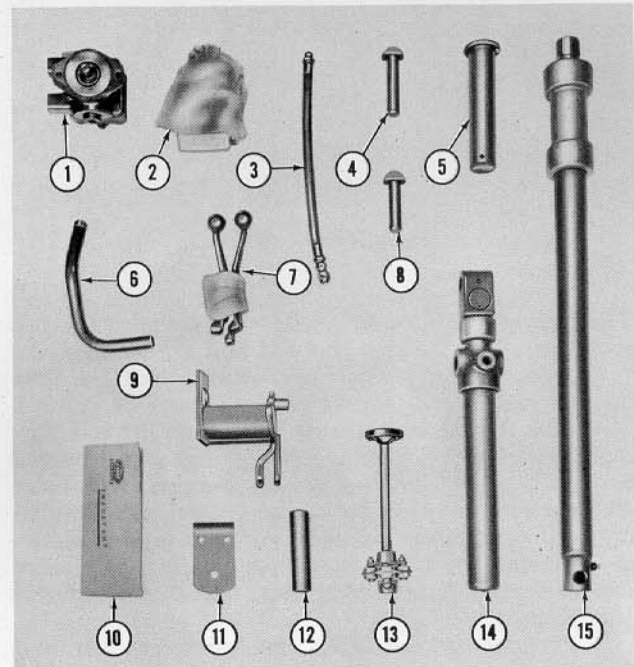

Figure 2
Contents of Bundle Number 194449

DEARBORN INDUSTRIAL LOADER

DEALER'S RESPONSIBILITY

It is the responsibility of the Ford Tractor and Dearborn Equipment dealer to assemble this loader, mount it on the tractor and to instruct the owner in its operation, care and maintenance.

ASSEMBLY PROCEDURE

The mounting and assembly of the loader can easily be done by two men; however, where a suitable chain fall or hoist is available, the loader may be completely assembled on the floor and then with the aid of the hoist, be positioned for mounting on the NAA tractor. In either case, certain work must be done on the tractor itself before the loader is mounted in place.

The tractor should be equipped with heavy duty front wheels (Part No. 8N-1015-B) and 6:00 x 16 heavy duty tires (sold separately). The tractor rear wheels should be set at a minimum distance of 56 inches, or at 52 inches when using the Fender Bracket Kit, D.M.C. Part No. 194447. Consult your Tractor Operator's Manual for the wheel setting procedure.

1. Open Bundle No. 194449 and lay out the parts to facilitate assembly.
2. Attach the drive plate (2), Figure 4, to the tractor crankshaft pulley (1) as follows:
 - a. Remove the crankshaft ratchet nut and four cap screws and lockwashers from the engine crankshaft. The crankshaft ratchet nut has a right hand thread. If possible, do not move the crankshaft pulley after removal of the cap screws.
 - b. Fit the flatwasher (1), Figure 3, on the special cap screw (2), and install the cap screw in place of the crankshaft ratchet nut which was removed.
 - c. Place the four $\frac{3}{16}$ " x 1" cap screws and lockwashers in the drive plate (3), Figure 3.
 - d. Position the assembly on the front of the crankshaft pulley (1), Figure 4, by working it through the opening (4) at the bottom of the engine suspension plate (5). Caution must be

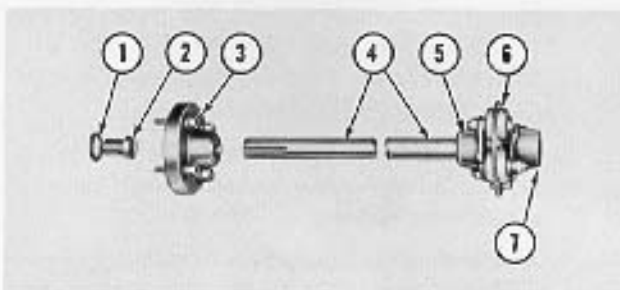

Figure 3

Drive Plate and Pump Drive Shaft

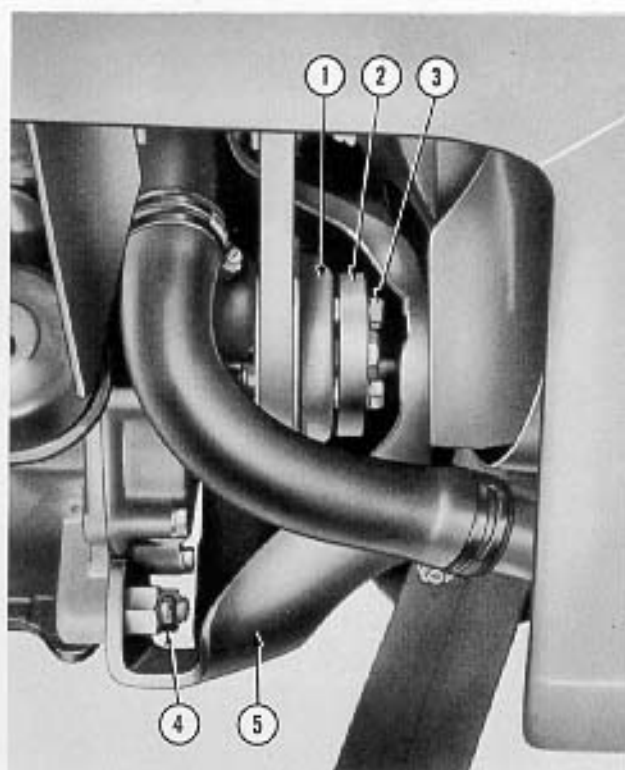

Figure 4

Pump Drive Plate Installed

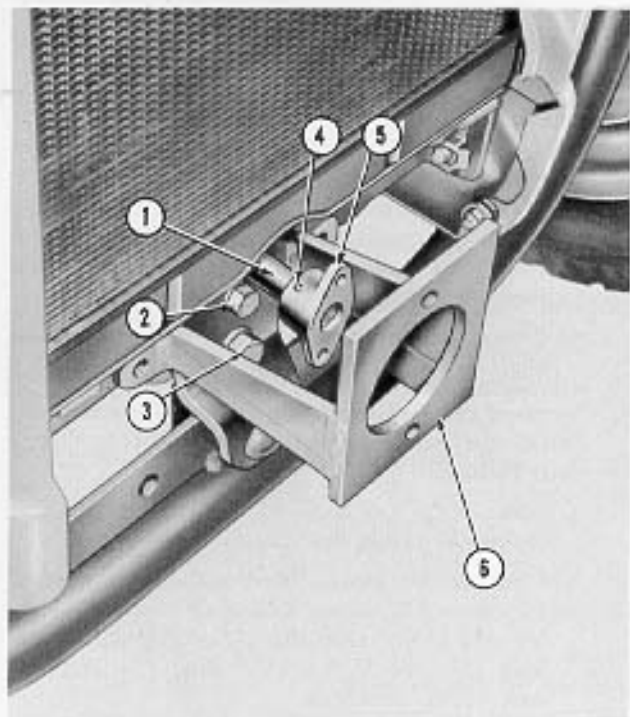

Figure 5

Loader Suspension Plate Installed

DEARBORN INDUSTRIAL LOADER

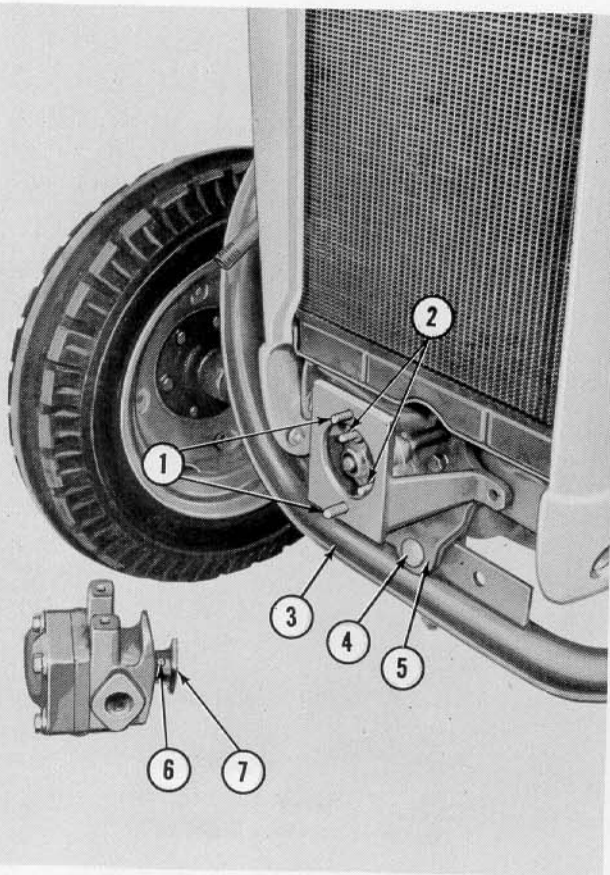

Figure 6

Front End of Main Frame Attached

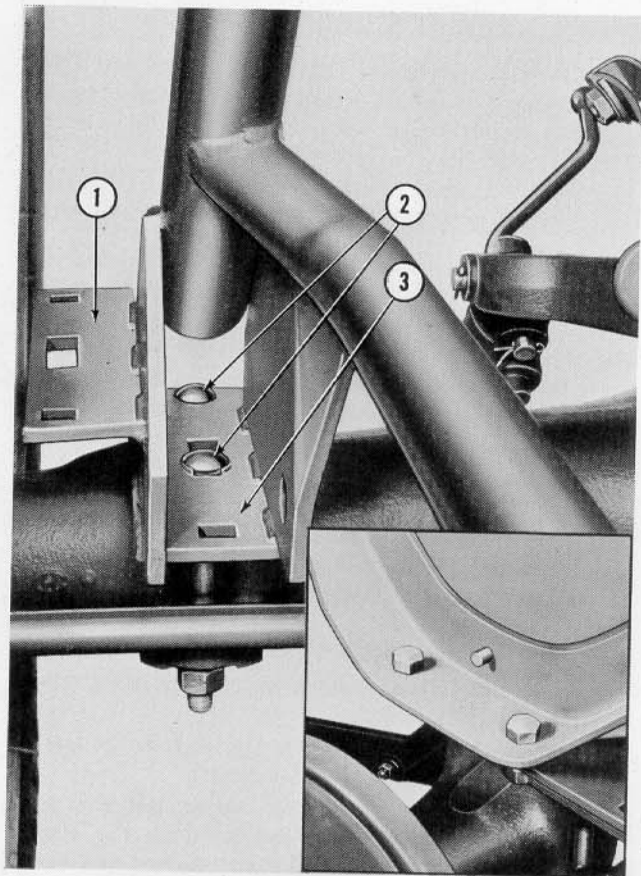

Figure 7

Rear End of Frame Attached

taken to position the drive plate without dropping the cap screws (3) from the drive plate or moving the crankshaft pulley (1). Make sure that all of the cap screws (3), Figure 4, are partially started in the holes of the crankshaft pulley before attempting to tighten them securely.

e. Use a thin wrench to tighten the cap screws (3), Figure 4.

3. Remove the radiator grille from the tractor and install the loader suspension bracket (6), Figure 5, as follows:

a. Remove the hex head bolt (2), Figure 5, and lockwasher from the front of the tractor.

b. Position the loader front suspension bracket (6), Figure 5, on the front axle support assembly and secure with the $\frac{1}{2}$ " x $1\frac{1}{2}$ " hex head bolt (2), the $\frac{5}{8}$ " x $1\frac{1}{2}$ " bolt (3) and the lockwashers provided.

4. Remove the flange (7), and coupling (6), Figure 3, from the pump drive shaft (4). Coat the shaft

splines with grease and insert the shaft in the crank hole until it is firmly seated in the splined drive plate (2), Figure 4. Loosen the Allen screw (4), Figure 5, and position the flange (5), on the shaft (1) so that the end of the shaft lacks about $\frac{1}{8}$ " of being flush with the face of the flange.

5. Mount the loader main frame on the tractor as follows:

a. Coat the threads of a $\frac{3}{4}$ " x 90° street ell with plumber's compound and turn it into the single outlet on the left side of the control valve. Next, coat the externally threaded end of a hose (3) Figure 12, and turn it into the street ell as shown at (4), Figure 12.

b. Remove both fenders from the tractor.

NOTE: The tractor rear wheels should be set at a minimum distance of 56 inches.

c. Attach the front end of the frame (3), Figure 6, to the clevis (5) on the loader suspension plate with the button head pin (4) and cotter pin provided.

DEARBORN INDUSTRIAL LOADER

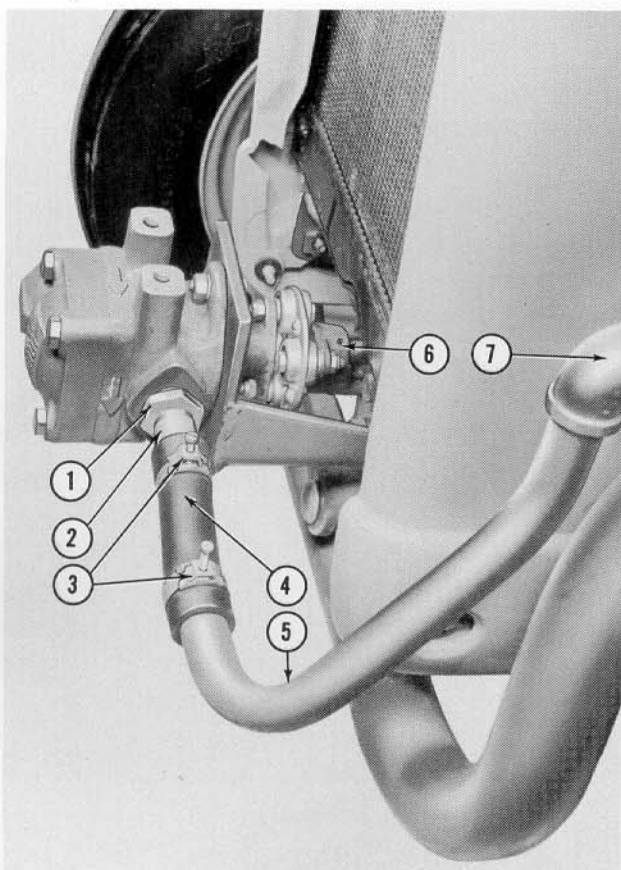

Figure 8
Loader Hydraulic Pump Installed

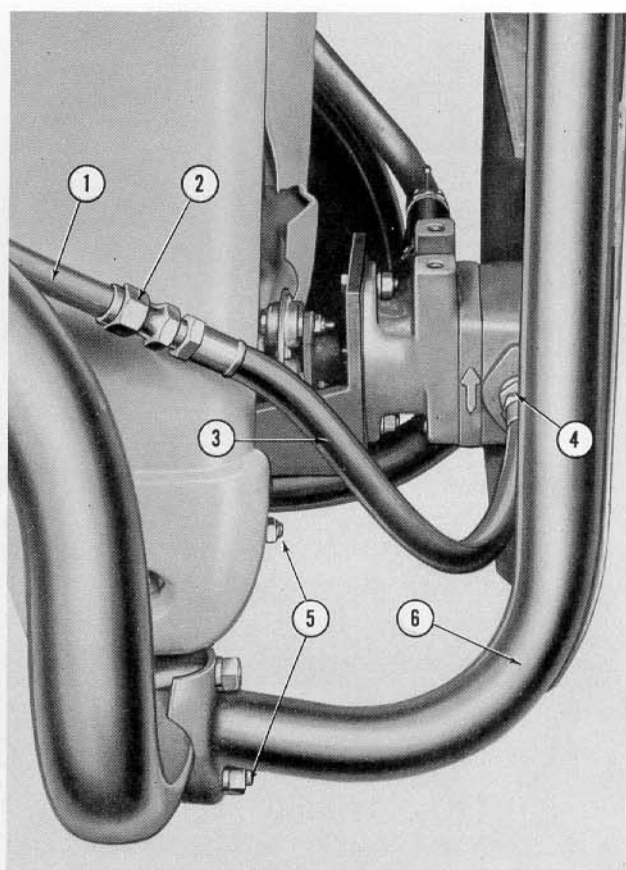

Figure 9
Bumper Assembly Attached

- d. Attach the rear end of the loader main frame (3), Figure 7, to the tractor left and right rear axle housing as shown. Use the original tractor fender bolts (2) and tighten securely.
6. Install the loader hydraulic pump as follows:
- Fit the flange (7), Figure 6, on the pump shaft with the Woodruff key in place and tighten the Allen head screw (6) securely.
 - Attach the coupling (6), Figure 3, to the flange (5), Figure 5, with the two bolts and locknuts provided.
 - Attach the hydraulic pump to the mounting bracket loosely with the bolts (1), Figure 6.
 - Reattach the flange (7), Figure 6, to the coupling with the two bolts (2) and locknuts provided.
 - Tighten the pump mounting bolts (1), Figure 6, securely. Make sure that the shaft is firmly seated in the splined drive plate and tighten the Allen head screw (6), Figure 8.
- f. Assemble the 1" to 3/4" reducer bushing (1), Figure 8, and the 3/4" x 3" nipple (2) and turn the reducer bushing into the left side of the hydraulic pump as shown in Figure 8.
- NOTE: To avoid leaking joints in the loader hydraulic lines and fittings, coat all threads with plumber's compound and tighten securely.
- Install the 3/4" pipe elbow (7), Figure 8, on the frame outlet and turn the curved pipe (5) into the elbow as shown.
 - Position the hose section (4), Figure 8, between the nipple and the curved pipe and tighten the clamps (3) securely.
 - Install the 1/2" x 3/8" reducer bushing (4), Figure 9, on the right side of the loader hydraulic pump.
 - Turn the externally threaded end of the hose section (3), Figure 9, into the reducer (4). Attach the internally threaded coupling (2) to the high pressure pipe (1) as shown.

DEARBORN INDUSTRIAL LOADER

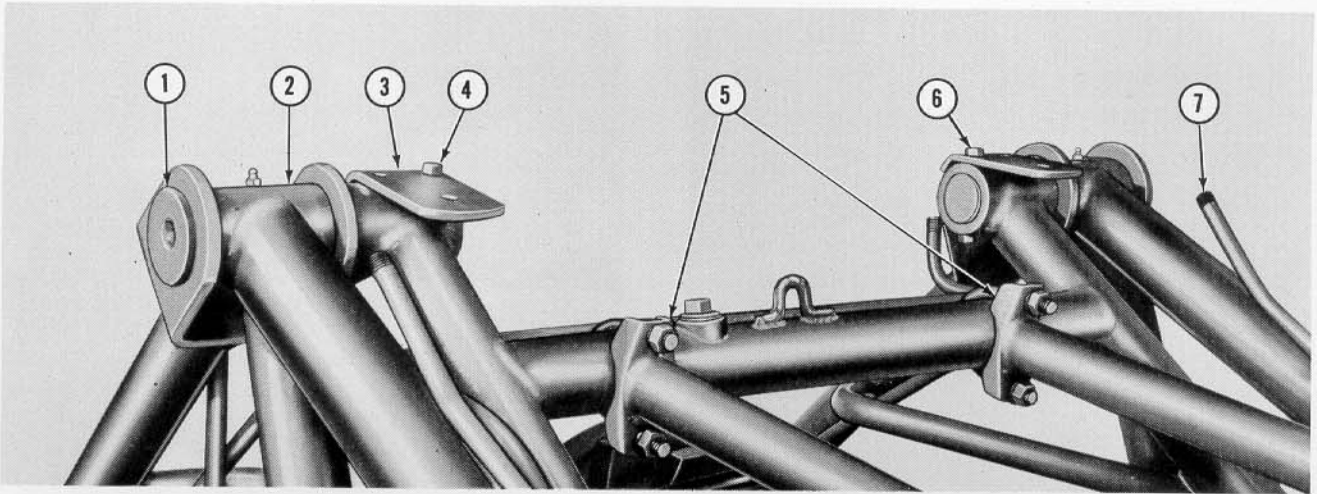

Figure 10
Loader Lift Arms Attached

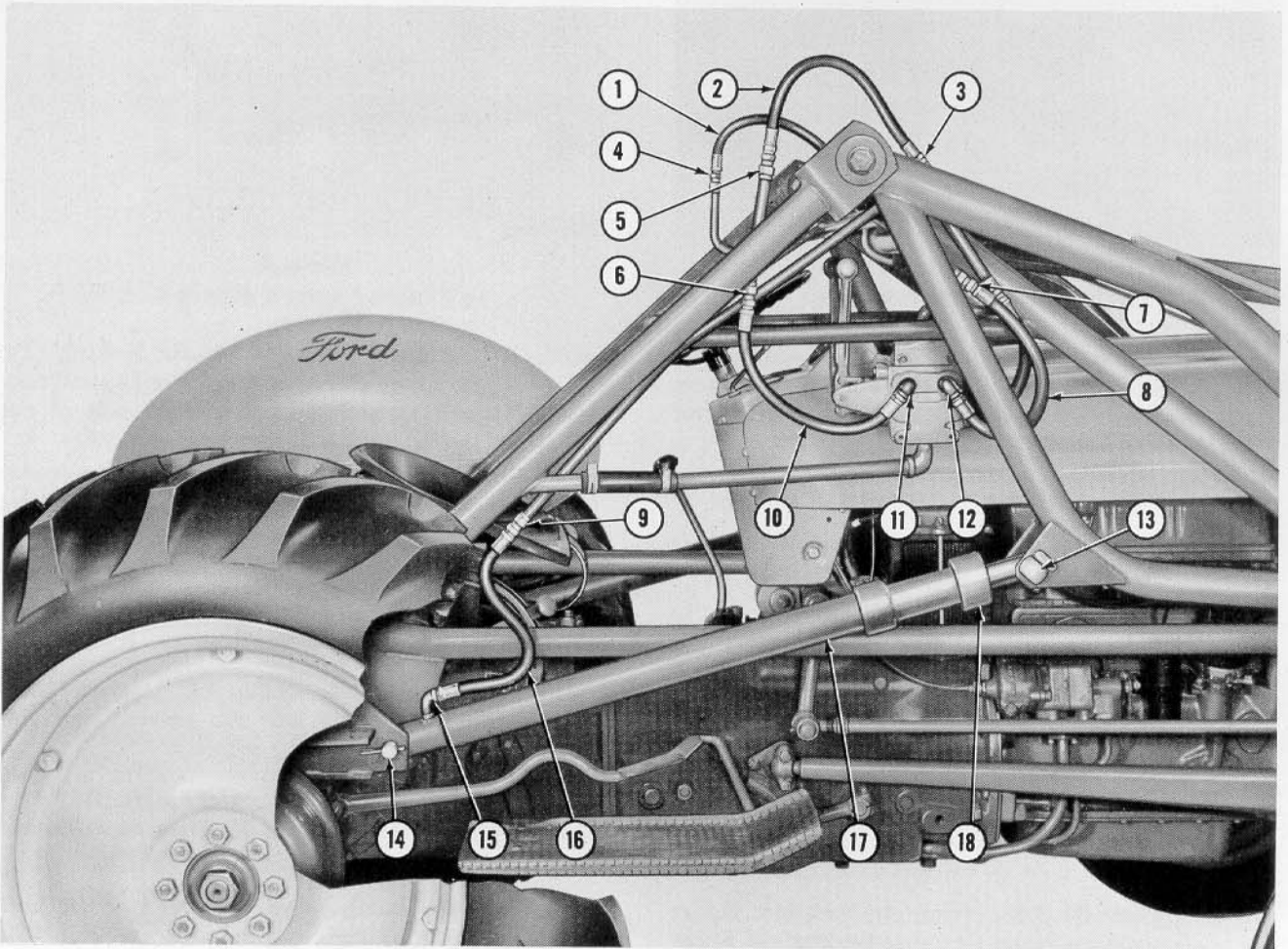

Figure 11
Lift Arm Cylinders and Hydraulic Lines Attached

DEARBORN INDUSTRIAL LOADER

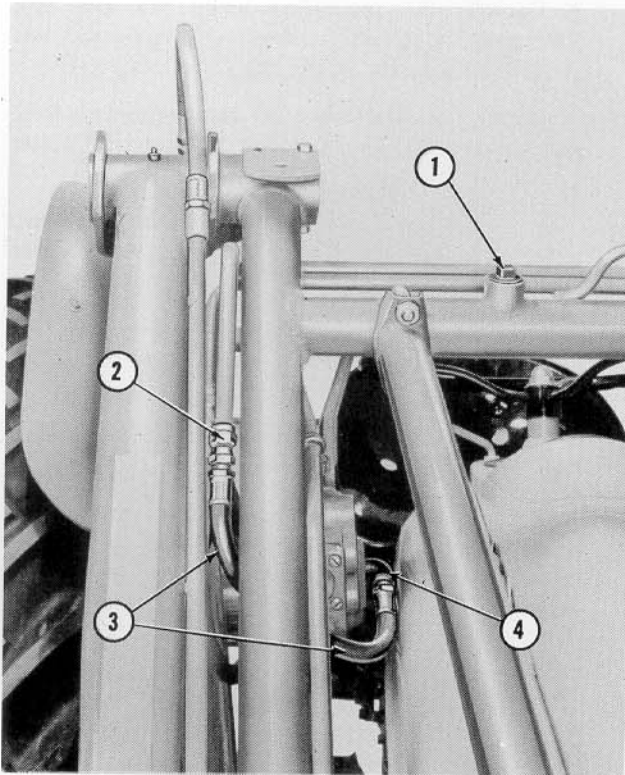

Figure 12
Control Valve Hydraulic Hose Attached

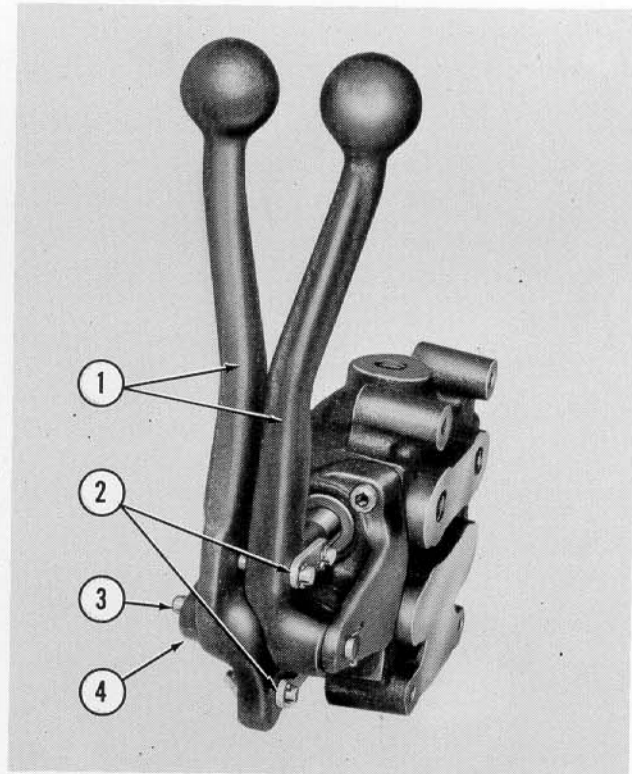

Figure 13
Levers Attached to Control Valve

7. Attach the bumper assembly (6), Figure 9, to the main frame with the four U-bolts, lockwashers and nuts, as shown at (5), Figures 9 and 10.
 8. Position the loader lift arm assembly on the loader frame so that the pivot pin holes are aligned. Insert a pivot pin (1), Figure 10, in each lift arm pivot yoke (2) as shown. Position a headlight bracket (3) on each side of the frame and secure the brackets and pivot pins with the bolts (4) and (6) as shown.
 9. Turn a $\frac{3}{8}$ " street ell (15), Figure 11, into the rear of each hydraulic cylinder (17) and tighten so that the ells point toward the front of the tractor. Turn a hose assembly (16), into the street ell on each cylinder.
 10. Attach the rear of a hydraulic cylinder (17), Figure 11, to each side of the frame assembly with a short pivot pin (14). Secure with a cotter pin as shown. Attach the front end of each cylinder to the lift arms with the pivot pins (13) and cotter pins provided.
- NOTE: The cap (18), Figure 11, on each lift arm cylinder should be tightened hand tight.
11. Connect each cylinder hydraulic hose (16), Figure 11, to the equalizer pipe end (9) on each side of the frame assembly.
 12. Turn a $\frac{3}{8}$ " pipe coupling on the end of the hose (2), Figure 11, and connect the coupling to the hydraulic line (3). Attach the other end of the hose to the vertical hydraulic line (5). Turn a $\frac{3}{8}$ " pipe coupling on the end of the hose (1), Figure 11, and connect the coupling to the hydraulic line (7), Figure 10. Attach the other end of the hose to the hydraulic line (4), Figure 11.
 13. Turn two $\frac{3}{8}$ " street ells (11) and (12), Figure 11, into the outlets on the right side of the hydraulic control valve.
 14. Turn the externally threaded end of a hydraulic hose (10), Figure 11, into the street ell (11) and connect the other end to the vertical hydraulic line at (6). Attach the hose (8) to the street ell (12) and connect the other end to the hydraulic line (7), as shown.
 15. Connect the free end of the hose assembly (3), Figure 12, to the equalizer pipe as shown at (2).
 16. Remove the masking material and paint from the exposed ends of the valve spools. Attach the control levers (1), Figure 13, to the valve spools with the linkage (2). Make sure that the levers are positioned as shown in Figure 13. Insert the pivot pin (3) through the control mounting bracket (4) and the control levers. Secure with the cotter pins provided.

DEARBORN INDUSTRIAL LOADER

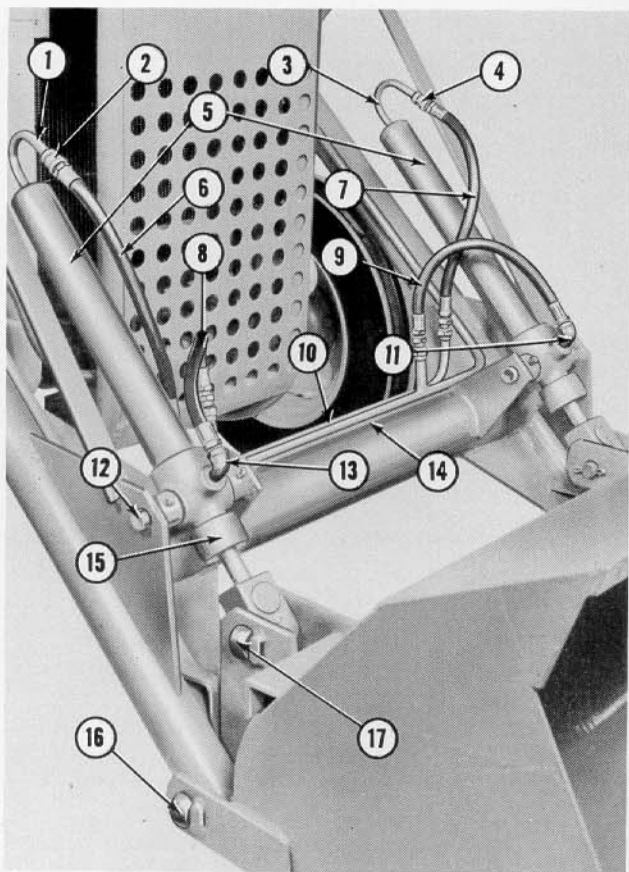

Figure 14
Bucket Assembly Attached

17. Mount the bucket control hydraulic cylinders on the loader lift arm assembly as follows:
 - a. Turn the reducer couplings (2) and (4), Figure 14, onto the pipes (1) and (3), and then turn the pipes into the ends of the cylinders (5) as shown.
 - b. Turn the street ells (11) and (13), Figure 14, into the cylinders.
 - c. Position the bucket cylinders (5) as shown in Figure 14 and attach each side of each cylinder to a support plate with a pivot pin (12) and cotter pin.

NOTE: The cap (15), Figure 14, on each bucket control cylinder should be tightened hand tight.
18. Attach the bucket control hydraulic lines as follows:
 - a. Turn the hydraulic hoses (6) and (7), Figure 14, into the reducer couplings (2) and (4). Attach the other ends to the outlets in the hydraulic line (10).

- b. Connect the remaining hoses (8) and (9), Figure 14, to the ends of the hydraulic line (14) and to the street ells (11) and (13).
19. Attach the bucket to the lift arms with two long pivot pins (16), Figure 14, and secure with cotter pins.
20. Attach each cylinder ram to the bucket with two pivot pins (17), Figure 14, and the cotter pins provided.
21. Attach the tractor fenders to the brackets (1), Figure 7, with the nuts and bolts provided. See insert, Figure 7.
22. Install the eight lubrication fittings, four on each side of the loader, as shown in Figure 15.
23. Add weight to the tractor rear tires with a calcium chloride solution as outlined in the Tractor Operator's Manual or by the use of wheel weights. The additional weight recommended is from 600 to 1200 pounds.

HYDRAULIC OIL

Before filling the loader with hydraulic oil, flush out the reservoir with kerosene or oil as follows:

- a. Remove the oil drain plug from the loader main frame.
- b. Disconnect the hose section (4), Figure 8, from the left side of the hydraulic pump by loosening the screw clamp (3).
- c. Place a drain pan under the drain hole and the disconnected hose section to catch the discharged kerosene or oil.
- d. Attach one end of a length of hose to the nipple (2), Figure 8. Place the other end in the oil or kerosene to be used for flushing.
- e. Start the tractor engine and flush the reservoir thoroughly.
- f. Replace the drain plug in the loader frame and flush through the frame outlet (5), Figure 8. Reattach the hose (4), Figure 8. Retighten the clamps (3) securely.

Fill the loader hydraulic oil reservoir as follows:

- a. Use approximately six (6) gallons of hydraulic oil, Ford Specification M-4864-D, or other hydraulic oil which meets this specification. See your local Ford Tractor and Dearborn Equipment dealer.
- b. Remove the 1" pipe plug (1), Figure 12.
- c. Fill the reservoir with approximately five (5) gallons of oil.
- d. Replace the filler plug loosely.

DEARBORN INDUSTRIAL LOADER

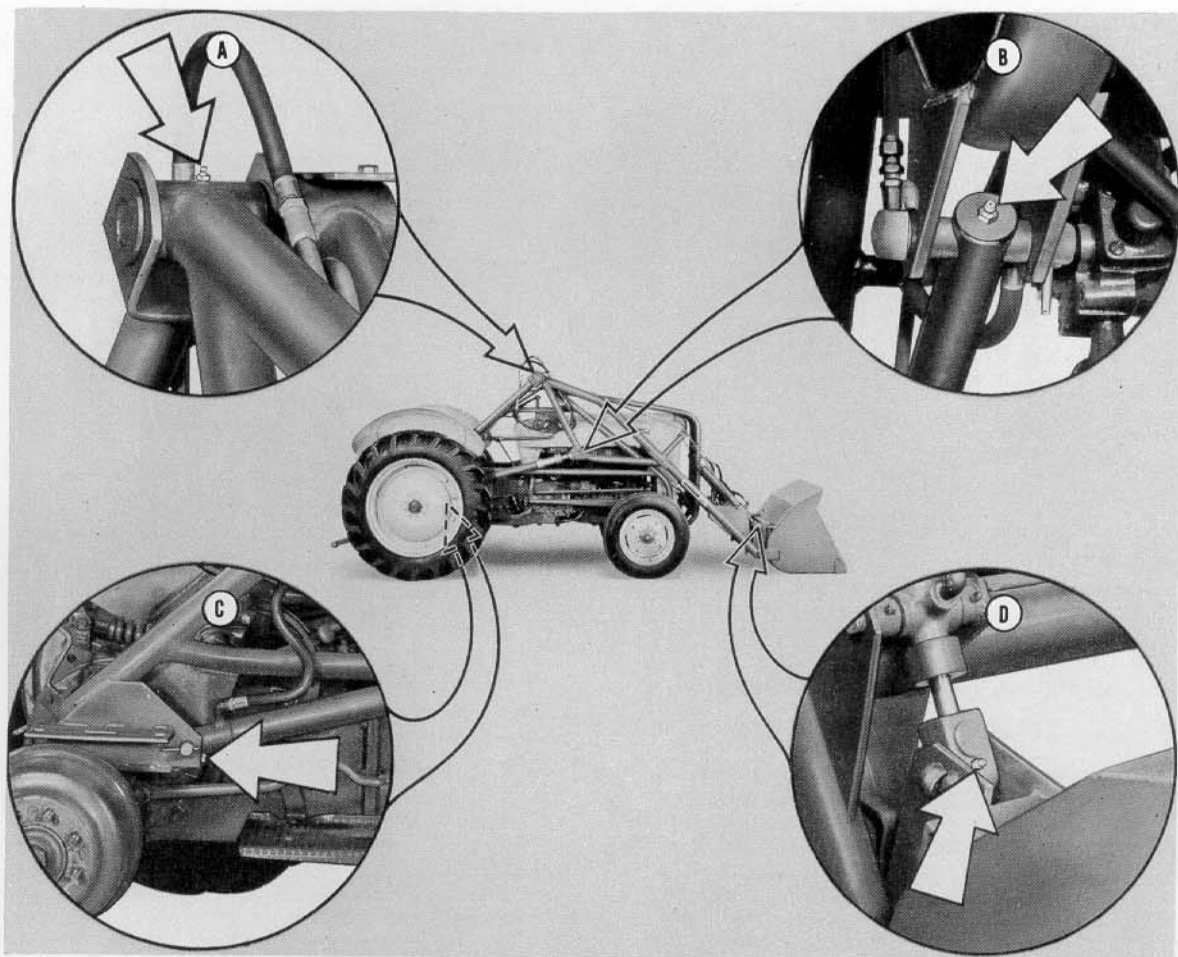

Figure 15
Lubrication Points on the Industrial Loader

- e. Operate the loader for about 15 minutes in order to bleed air from the system.
- f. Add approximately one gallon of oil to fill the frame completely and install the filler plug tightly.
- g. Check all pipe connections and hydraulic lines for loose or leaking joints.

After the loader has been operated for approximately 25 hours, the reservoir should be flushed out as directed above. This will eliminate any particles of foreign material which may have been loosened during loader operation. The hydraulic oil may be used again if it is carefully filtered through a cloth.

After 1000 hours or 1 year of operation (whichever is shorter), the loader reservoir should be drained and again filled with new hydraulic oil.

LUBRICATION

There are eight grease gun fittings on the Dearborn Industrial Loader: one on the pivot sleeve of each lift arm (A), Figure 15, one on the piston shaft of each hydraulic cylinder (B), one on the rear end of each hydraulic cylinder (C), and one on the ram of each bucket cylinder (D). Lubricate the loader immediately after assembly and every eight hours of operation thereafter. Also, oil the two pins which support each bucket control cylinder. See (12), Figure 14.

OPERATION

The Dearborn Industrial Loader should be operated at moderate tractor speeds to avoid spillage and loss of control. Excessive operating speeds are dangerous and may cause unnecessary strain. The tractor engine speed should be 1200 to 1500 R.P.M. and the tractor operated in second gear.

DEARBORN INDUSTRIAL LOADER

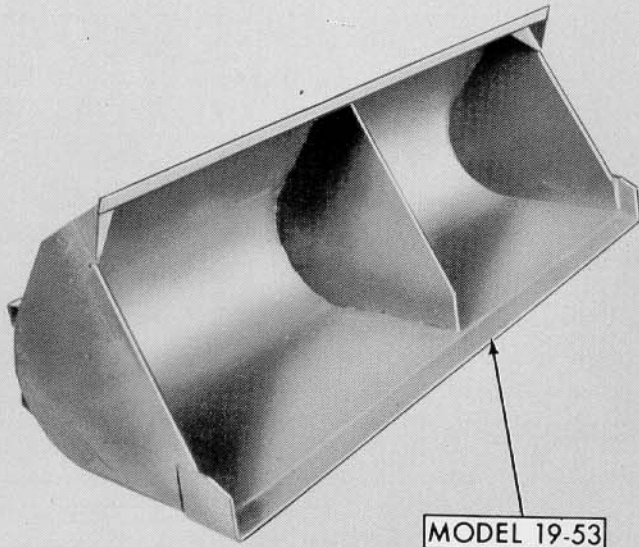

MODEL 19-53

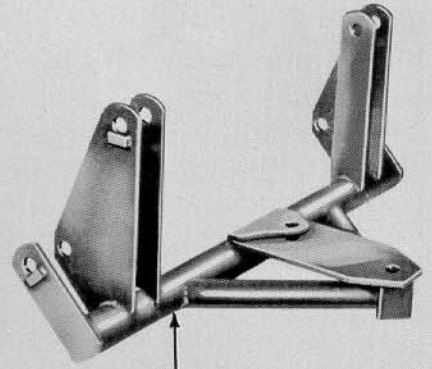

MODEL 19-54

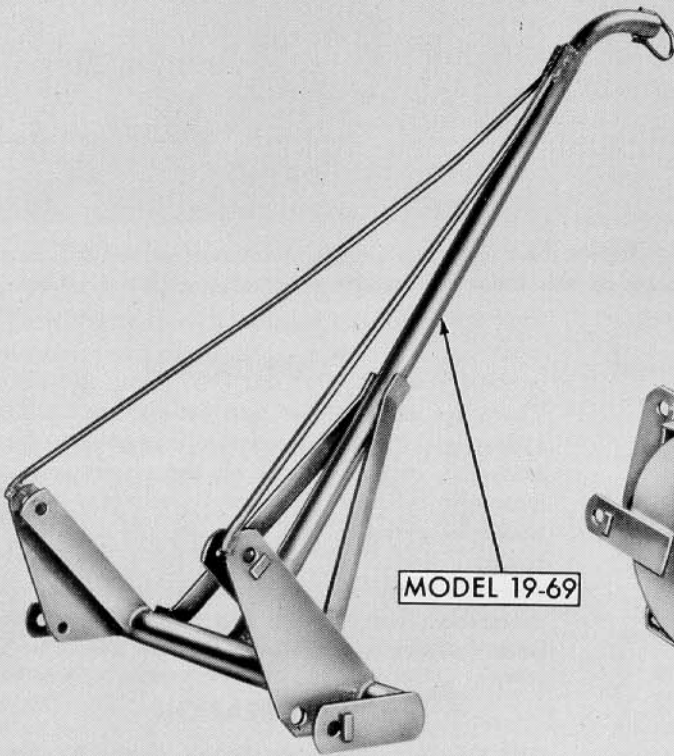

MODEL 19-69

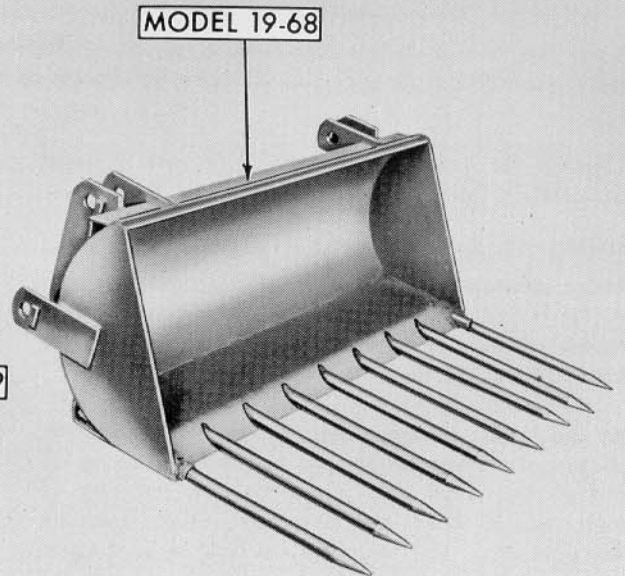

MODEL 19-68

Figure 16

Attachments for the Dearborn Industrial Loader

DEARBORN INDUSTRIAL LOADER

The loader lift arms are raised by pulling the inner valve lever to the rear and lowered by pushing the same lever forward. To dump the bucket, pull the outer valve lever to the rear. To return the bucket to its operating position, push forward on the outer valve lever. Both levers may be pushed forward together, so that the lift arms will lower and the bucket will return simultaneously. The loader operation is sufficiently fast for complete action during a normal amount of tractor maneuvering.

Drive straight into the pile when crowding a load into the bucket. Do not overtax the loader by trying to fill the bucket while turning. When loading from a pile of material, keep the surrounding area clean to maintain better traction and more efficient operation. The best procedure is to load from a vertical wall of material so that it will break away and fall into the bucket for maximum fill on each load. Load the bucket with short, forward thrusts and raise the lift arms a little each time. Do not try to fill the bucket with one thrust into the material, as this results in less efficiency and causes unnecessary strain on the loader, the tractor and the operator. The Industrial Loader does not utilize the Ford Tractor Hydraulic System and it, therefore, is free to be used for other implements such as the Danuser All Purpose Blade, Utility Blade, etc.

The Trouble Shooting Chart on pages 11 and 12 is provided to aid the operator in quickly recognizing operational problems, their general cause and corrections.

TRANSPORTING

When transporting the loader with the bucket loaded or empty, the lift arms should be raised to a height where the bucket is just below the level of the tractor hood. Maximum stability and visibility are obtained when the lift arms are in this position.

ATTACHMENTS

A wide variety of attachments, ideally suited for industrial purposes, are available for use on the Dearborn Industrial Loader. These attachments, which are

sold separately by your Dearborn Equipment dealer, are listed below and shown in Figure 16.

Material Bucket, Model 19-43. (See cover illustration)

Snow Bucket, Model 19-53.

Manure Fork, Model 19-68.

Crane, Model 19-69.

The Adaptor Unit, Model 19-54, Figure 16, permits installation of the following equipment.

Angle Dozer Blade, Model 19-2.

Blade Snow Plow, Model 19-3.

V-Snow Plow, Model 19-4.

A Fender Bracket Kit (D.M.C. Part No. 194447) is available for use on the NAA tractor. This kit permits installation of tractor fenders with a rear wheel tread of 52 inches when dual 11-28 rear tractor tires are being used. The brackets are easily attached over the rear mounting plates of the loader.

OPERATIONAL MAINTENANCE

1. Check the level of oil in the loader system daily.
2. Have hydraulic oil leaks serviced promptly to avoid loss of oil and damage to the system.
3. When not in use, clean the exposed parts of the control valve spools, cylinder rods, and drive shaft and coat with rust preventive.
4. Lubricate the loader as directed in this manual.
5. Store the loader in a clean, dry place if possible.
6. Inspect the hydraulic hoses for wear at frequent intervals.
7. Use touch-up paint as necessary to prevent rust and to maintain the appearance of the loader.
8. Your Ford Tractor and Dearborn Equipment dealer stocks genuine Ford Tractor and Dearborn Equipment repair parts. These parts are manufactured and inspected to assure high quality and accurate fit. Insist on genuine Ford Tractor and Dearborn Equipment repair parts.

DEARBORN INDUSTRIAL LOADER

TROUBLE SHOOTING

The following material on trouble shooting is presented to aid the operator in quickly recognizing operational problems, their general cause and the remedy.

LOADER

<i>Problem</i>	<i>Possible Cause</i>	<i>Correction</i>
Pump and/or valve noisy	<ol style="list-style-type: none">1. Cavitation caused by low oil level.2. Cavitation caused by foaming oil.3. Pump shaft seal leaks.4. Intake hose leaks.5. Intake hose or fittings loose.6. Broken rotor.7. Worn rotor housing.8. Relief valve pressure too high.9. Filler cap loose.10. Oil too heavy.	<ol style="list-style-type: none">1. Correct leaks in system and maintain full reservoir.2. Use proper type of hydraulic oil.3. Replace seals.4. Replace hose.5. Tighten clamps and fittings.6. Replace rotor.7. Replace housing.8. Check and adjust using pressure gauge.9. Tighten cap.10. Use proper type oil or thin.
Slow or erratic rate of lift	<ol style="list-style-type: none">1. Low pump efficiency.2. Valve spools not properly centered.3. Relief pressure too low.4. Low oil level.5. Foaming oil.	<ol style="list-style-type: none">1. Replace worn or damaged parts.2. Adjust valve spools.3. Check and adjust with pressure gauge.4. Correct leaks in system and maintain full reservoir.5. Use proper type of hydraulic oil.
Bucket drops under load	<ol style="list-style-type: none">1. Piston cups cut, worn or loose.2. Cylinder bore not smooth.3. Oil bypassing at control valve.	<ol style="list-style-type: none">1. Replace and install properly.2. Replace cylinder.3. Replace valve.
Lift arms drop under load	<ol style="list-style-type: none">1. Oil bypassing at control valve.2. Pump worn and overheats.	<ol style="list-style-type: none">1. Replace control valve.2. Repair pump.
Low lift capacity	<ol style="list-style-type: none">1. Low pump efficiency.2. Relief pressure too low.	<ol style="list-style-type: none">1. Replace worn or damaged parts.2. Check and adjust with pressure gauge.

HYDRAULIC OIL LEAKAGE

Cylinder "O" rings	<ol style="list-style-type: none">1. Cut in installation.2. Rough or burred cylinder O.D.3. Cylinder tube undersize causing extrusion.	<ol style="list-style-type: none">1. Replace "O" rings.2. Remove sharp edges with crocus cloth and replace ring.3. Replace tube.
Pump "O" rings	<ol style="list-style-type: none">1. Cut in assembly.2. Pump cover not tight causing extrusion.	<ol style="list-style-type: none">1. Replace rings.2. Torque to 70 foot lbs.
Cylinder packings	<ol style="list-style-type: none">1. Worn packing lip.2. Damaged in assembly.3. Cut by a burr or scored rod.	<ol style="list-style-type: none">1. Replace packing.2. Replace packing.3. Remove burr or replace rod.
Pump seals	<ol style="list-style-type: none">1. Shaft burred or scored.2. Worn seals.3. Abrasives in system.	<ol style="list-style-type: none">1. Replace shaft and seal.2. Replace seal.3. Flush system as recommended.

DEARBORN INDUSTRIAL LOADER

<i>Problem</i>	<i>Possible Cause</i>	<i>Correction</i>
Valve seals	<ol style="list-style-type: none"> 1. Paint ring or masking tape on spindle. 2. Score or rough finish on spindle. 	<ol style="list-style-type: none"> 1. Remove paint or tape and replace seals. 2. Replace valve.
PUMP		
Rotor embedded with metal particle—body galled	<ol style="list-style-type: none"> 1. Insufficient lubrication. 	<ol style="list-style-type: none"> 1. Use proper type hydraulic oil.
Rotor, body and/or pressure plate scored or scratched	<ol style="list-style-type: none"> 1. Abrasives or dirt in system. 	<ol style="list-style-type: none"> 1. Flush as recommended.
Pump cover plate broken	<ol style="list-style-type: none"> 1. Cap screws loose. 	<ol style="list-style-type: none"> 1. Replace and torque to 70 ft. lbs. Check "O" ring for extrusion.
Pump burst	<ol style="list-style-type: none"> 1. High pressure. 	<ol style="list-style-type: none"> 1. Check relief valve with pressure gauge and adjust.
Rotor housing (ring) ridged	<ol style="list-style-type: none"> 1. Cavitation. 	<ol style="list-style-type: none"> 1. Check oil level—type of hydraulic oil. Check for leaks at pump intake.
Worn drive shaft	<ol style="list-style-type: none"> 1. Partial engagement. 2. Tractor front axle support failure. 3. Misalignment. 	<ol style="list-style-type: none"> 1. Adjust. 2. Repair or replace. 3. Check installation of hub and pump mounting bracket.
Rotor segment broken	<ol style="list-style-type: none"> 1. Vanes too loose in slots. 	<ol style="list-style-type: none"> 1. Replace rotor.
Vanes worn prematurely to taper	<ol style="list-style-type: none"> 1. Cavitation—Low oil level. 2. Insufficient lubrication. 	<ol style="list-style-type: none"> 1. Check oil level—Type of oil. 2. Replace vanes—Inspect ring.
Vanes scored	<ol style="list-style-type: none"> 1. Abrasives in system. 	<ol style="list-style-type: none"> 1. Flush system as recommended. Inspect all pump parts.
Pump shaft seal leaks	<ol style="list-style-type: none"> 1. See pump seal leakages. 	
"O" rings extruded	<ol style="list-style-type: none"> 1. See Pump "O" ring leakages. 	
Pump will not deliver pressure even when appears O.K.	<ol style="list-style-type: none"> 1. Rotor housing ring assembled incorrectly. Pressure plate spring omitted. 	<ol style="list-style-type: none"> 1. Assemble properly with arrow pointing in direction of crankshaft rotation.
Premature bearing failure	<ol style="list-style-type: none"> 1. Drive shaft misalignment. 	<ol style="list-style-type: none"> 1. Replace bearing. Align shaft.
VALVE		
Levers stick	<ol style="list-style-type: none"> 1. Lever binds against frame. 2. Valve spool binds. 	<ol style="list-style-type: none"> 1. Assemble correctly. 2. Disassemble and inspect for dirt or scoring.
Bypass oil in neutral	<ol style="list-style-type: none"> 1. Spools pitted by corrosion. 2. Spools scored. 3. Bores damaged. 	<ol style="list-style-type: none"> 1. Replace body and spools. 2. Replace body and spools. 3. Replace body and spools.
Relief valve does not hold pressure	<ol style="list-style-type: none"> 1. Relief valve gasket not sealing. 2. Foreign object holds valve open. 3. Pressure setting too low. 4. Burred or scored relief piston or seal. 5. Broken relief spring. 	<ol style="list-style-type: none"> 1. Replace copper gasket. 2. Disassemble valve and clean. 3. Check pressure with gauge and adjust. 4. Remove burr with crocus cloth or replace assembly. 5. Replace spring.